

Armadale Line Upgrade Project

Victoria Park Early Works Development Application No. 1 – Viaduct Construction and Enabling Works

October 2022 | 21-311



ARMADALE LINE UPGRADE ALLIANCE

Document Control Record

Document Prepared by:

element

Level 18, 191 St Georges Terrace,

Western Australia 6000

T 9289 8300

E hello@elementwa.com.au

Document Control

Report Title	Armadale Line Upgrade Project - Victoria Park Early Works Development Application No. 1 – Viaduct Construction and Enabling Works					
Client	ALUA					
Rev	Date	Revision Details / Status	Author	Reviewer	Verifier (If required)	Approver
A	02/08/22	Draft	Renee Young and Murray Casselton	Ben Johnston		
B	04/08/22	Draft	Renee Young and Murray Casselton	Ben Johnston		
C	16/09/22	Final for approval	Renee Young and Murray Casselton	Ben Johnston		
D	07/10/22	Final	Renee Young and Murray Casselton	Ben Johnston		
Current Revision	Rev D					

Approval

Author Signature			Approvers Signature
Name	Renee Young	Murray Casselton	Name
Title	Associate	Director	Title

We acknowledge the Whadjuk people of the Noongar nation as traditional owners of the land on which we live and work.

We acknowledge and respect their enduring culture, their contribution to the life of this city, and Elders, past and present.

Contents

Executive Summary	5	Appendix A – Detailed Site Description	46
Abbreviations	11	Site Description	46
1. Introduction	12	Site Context	48
1.1 Project Overview	18	Reservations and Zonings	48
1.2 Project Team	20	Environmental Considerations	51
1.3 Planning Approval Pathway	20	Appendix B – Requirement for	
1.4 Related Approval Processes	21	Planning Approval	52
2. Project Background	22	Appendix C – Detailed Planning	
3. Preliminary Consultation Summary	24	Assessment	53
3.1 Pre-Lodgement Agency and Community Consultation	24	State Planning Strategy 2050	53
4. Site Analysis and Design Response	25	Perth and Peel @3.5 Million	53
4.1 Design Principles	25	Metropolitan Region Scheme	54
4.2 State Design Review Panel Engagement	27	Planning Control Area No.165	54
5. Description of Proposed Development	28	State Planning Policies	54
5.1 Development Overview	28	Town of Victoria Park Local Planning Strategy	55
5.2 Extent of Works and Exempt Works	29	Town of Victoria Park Local Planning Scheme No. 1	56
5.3 Early Works	30	Town of Victoria Park Precinct Plans	56
5.4 Viaduct Piers and Structure	30	Town of Victoria Park Local Planning Policies	57
5.5 Tree Removal	35	Appendix D – Certificates of Title	59
5.6 Project Delivery and Staging	35	Appendix E – PCA Boundary	60
6. Key Planning and Design		Appendix F – Civil Structures and	
Considerations	36	Viaduct Drawings (Plans, Elevations,	
6.1 Relationship with Surrounding Urban Context	36	Typical Sections)	61
6.2 Applicable Planning Framework	36	Appendix G - Retaining Walls and	
6.3 Crime Prevention Through Environmental Design	38	Abutment Plans (Plans, Elevations,	
6.4 Sustainability Approach	39	Typical Sections)	62
7. Key Technical Considerations	40	Appendix H – Work Zones and Tree	
7.1 Acoustic and Vibration Considerations	40	Management Plans	63
7.2 Construction and Traffic Management	41	Appendix I – Construction	
7.3 Geotechnical Considerations	43	Management Plan	64
7.4 Contaminated Land	43	Appendix J – Operational Noise	
7.5 Water Management	43	and Vibration Assessment (2022)	65
7.6 Services and Infrastructure	44	Appendix K – Services Alteration and	
8. Conclusion	45	Relocation Concept Plans	66
		Appendix L – Basic Summary of Records	67

Armadale Line Upgrade Project

Victoria Park Early Works Development Application No. 1 – Viaduct Construction and Enabling Works



Executive Summary

The Victoria Park-Canning Level Crossing Removal Project (VPCLXR) forms part of the METRONET rail program, which represents the single largest investment in public transport that Perth has seen. In delivering approximately 77 kilometres of new passenger rail and 22 new train stations, the METRONET rail program acts as a catalyst to turn more than 8,000 hectares of land around new stations into desirable places to live, work and play.

The VPCLXR project is Perth's first major elevated rail line that will improve public transport safety, reduce traffic congestion and create new publicly accessible spaces for ongoing use by the community within the existing rail corridor. The VPCLXR project includes the following key components:

- Three sections of new elevated rail line, or viaduct, comprising piers, pier headstock and 'U trough/s'.
- The removal of six (6) existing level crossings at Mint Street, Oats Street, Welshpool Road, Hamilton Street, Wharf Street and William Street.
- The development of five (5) new, modern elevated train stations at Carlisle, Oats Street, Queens Park, Cannington and Beckenham.
- The removal of the existing Welshpool Train Station.
- New station precincts at ground plane level around each of the new train stations including bus facilities at Oats Street and Cannington Stations, patron parking and landscaping.
- New ground level public realm works between station precincts incorporating public spaces and facilities.

It was determined very early in the planning phases to make the VPCLXR project an elevated rail line, as opposed to putting the rail line underground. In this regard the extensive early planning undertaken by the State Government determined that an underground rail solution was an unfeasible option, due to the availability of land for the project within the existing MRS Railways Reservation, the cost differential (both capital and ongoing operational costs) for sinking the rail rather than elevating it and, given the success of similar elevated rail projects in the Eastern States.

This development application relates to one of the major project components only, being the elevated rail line (viaduct) and associated structures that support this piece of infrastructure. Specifically, this application seeks approval for the following:

- Early works and site establishment works (including removal of vegetation, crane pads, and gantry work zones).
- Piling for the viaduct.
- Viaduct piers and structure.
- Operational railway infrastructure / works (i.e. rail track, maintenance tracks, signalling infrastructure, OLE masts, overhead rail lines and infrastructure etc).
- Alteration or relocation of existing services (including overhead power lines, drainage, water and gas infrastructure) where these are located within the rail corridor;
- Electricity works for the railway.
- Temporary work zones within the rail corridor.
- Demolition of existing train stations (including Welshpool Train Station).

It is noted that the details of architectural screens and/or paint finishes that will form part of the viaduct design are not resolved at this stage. It is proposed that the future provision of these details will be subject to relevant conditions on the approval.

This application is for the early enabling and key structural components of the VPCLXR project only. As set out below, future separate development applications will be prepared and submitted for the remaining components of the VPCLXR project, which includes the new train stations, public car parking (park and ride facilities), bus interchange facilities and the public realm treatments below and around the viaduct that will deliver the new public spaces and facilities. These future applications will be advertised for public information and comment at the appropriate time.

Armadale Line Upgrade Project

Victoria Park Early Works Development Application No. 1 – Viaduct Construction and Enabling Works

This application relates to the early works and elevated rail infrastructure and associated works that are located in the Town of Victoria Park (the Town). The proposed works are located both within the rail corridor and Planning Control Area No.165 (PCA), which extends generally from Mint/Archer Streets to Briggs Street as shown in Figures 1, 2, 3 and 4. A PCA is an enabling planning mechanism that allows the development application for this significant public infrastructure to be considered and determined by the Western Australian Planning Commission (WAPC).

Refer to Figure 1 – Location Plan

Refer to Figure 2 – Aerial Plan

Refer to Figure 3 – Indicative extent of VPCLXR viaduct Work Included in the Development Application

Refer to Figure 4 – Concept diagram of extent of VPCLXR Project

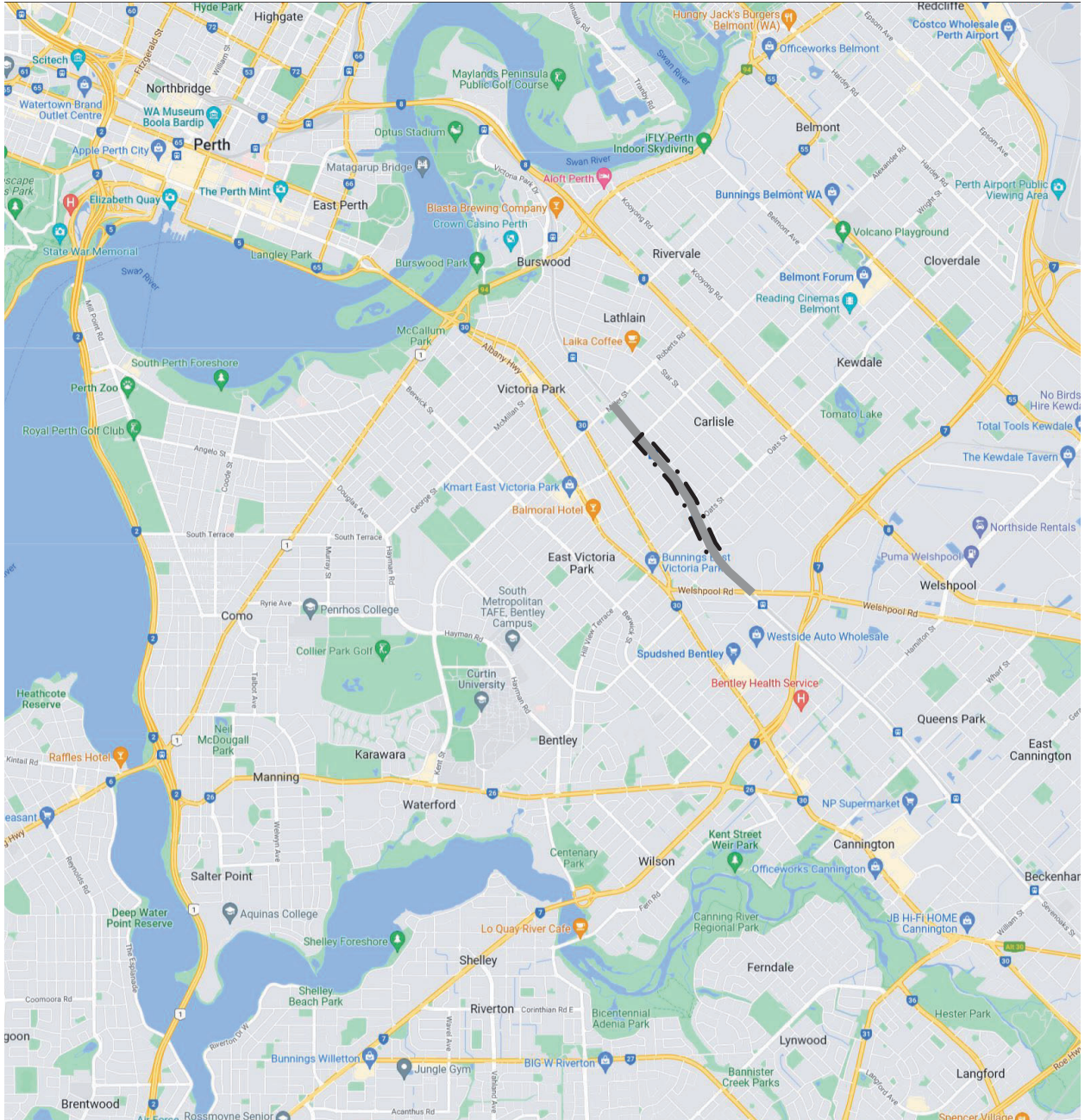

 Subject Site  VPCLXR Project Extent in the Town of Victoria Park

source: googlemaps

Figure 1. Location Plan

Armadale Line Upgrade Project

Victoria Park Early Works Development Application No. 1 – Viaduct Construction and Enabling Works



Figure 2. Aerial Plan

VPCLXR Project - Indicative Extent of Works included in the Development Application

- █ Indicative extent of Planning Control Area (PCA)
- █ Location of new stations (subject to separate future development applications)
 - 1 Carlisle
 - 2 Oats Street
 - 3 Queens Park
 - 4 Cannington
- *Existing stations (including Welshpool) to be demolished
- █ Retaining Walls/Embankments Structure - outside of PCA & exempt from development approval

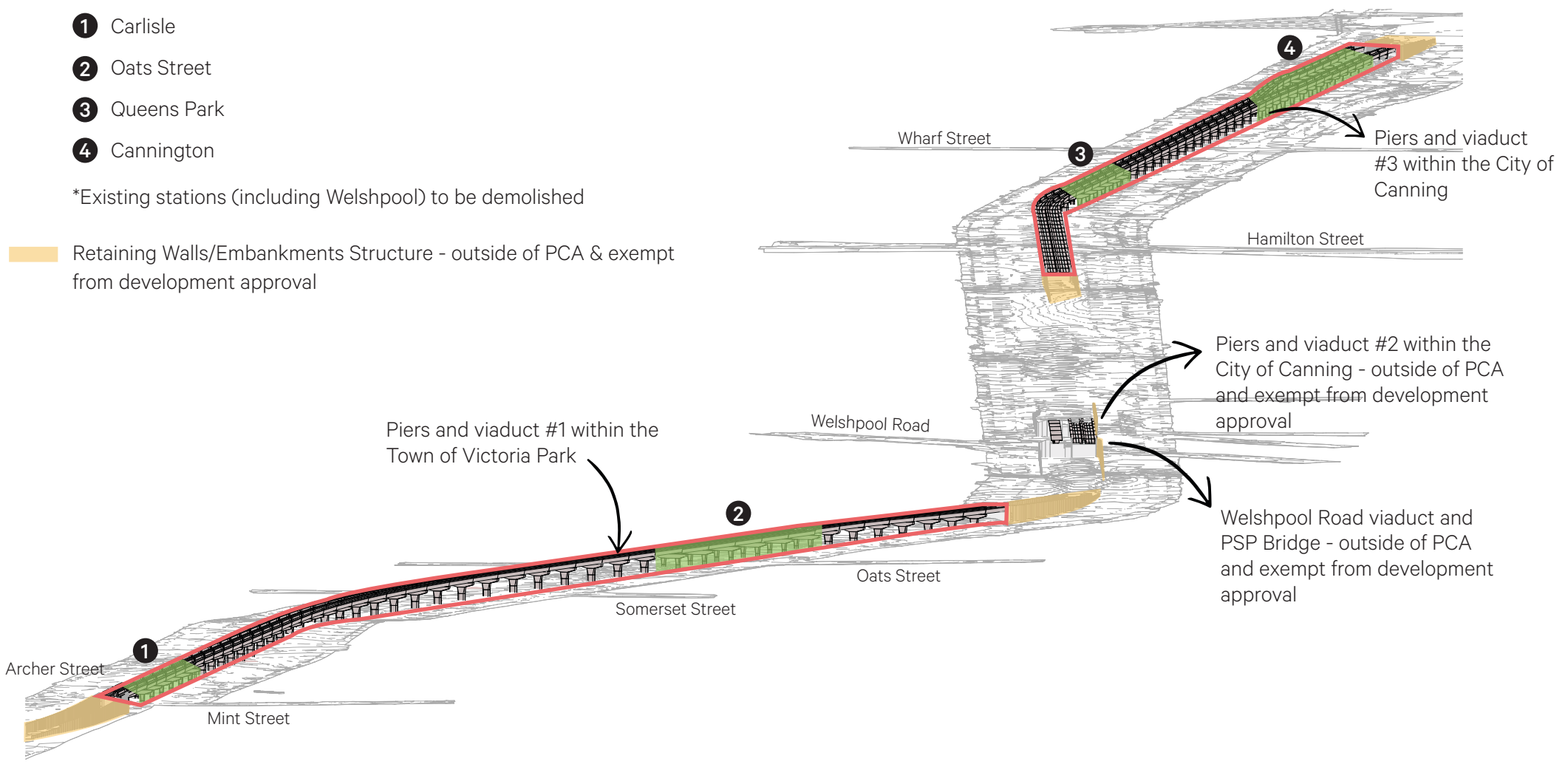

Figure 3. Indicative extent of VPCLXR viaduct Work Included in the Development Application

Armadale Line Upgrade Project

Victoria Park Early Works Development Application No. 1 – Viaduct Construction and Enabling Works

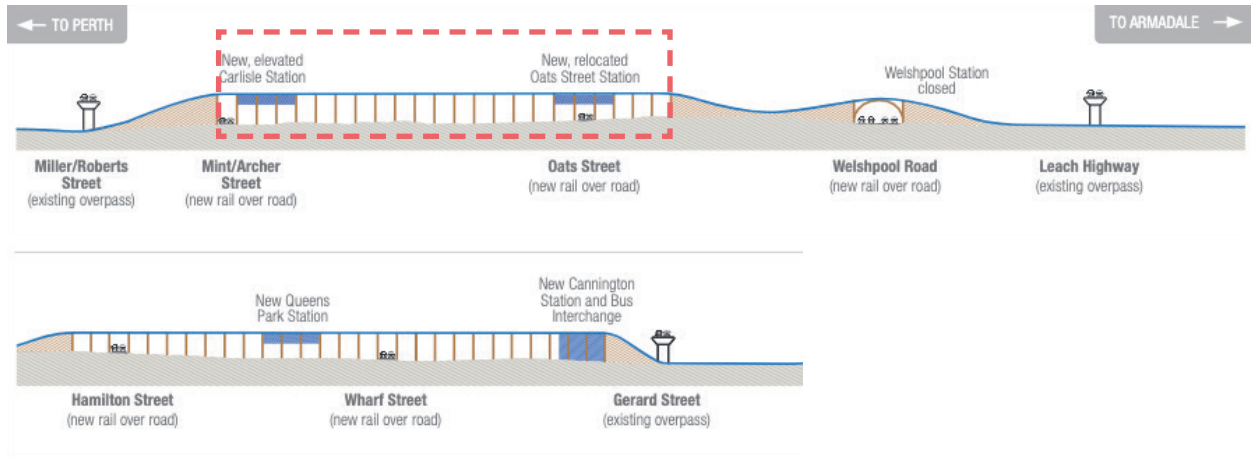

Figure 4. Concept diagram of extent of VPCLXR Project, with the extent of the viaduct that is the subject of this development application shown highlighted in red outline (note that new stations will be subject to future separate development applications) (source: METRONET 2022)

A separate simultaneous development application focusing on the elevated rail infrastructure and associated works within the Town of Victoria Park (the Town) has also been prepared and submitted for consideration. Together, these applications will allow for early enabling works and key structural works to occur as critical components of the overall project, ensuring an efficient delivery timeframe for the VPCLXR project. Applications for the City of Gosnells section of the VPCLXR project will be submitted in the future once the design work for this section of the rail is ready.

The VPCLXR project will be delivered by the Armadale Line Upgrade Alliance (ALUA) on behalf of the Office of Major Transport Infrastructure Delivery (OMTID) and the rail operator Public Transport Authority of Western Australia (PTA). The project is expected to be completed in the first half of 2025.

Abbreviations

Abbreviation	Definition
CRGs	Community Reference Groups
DAs	Development Applications
DWER	Department of Water and Environmental Regulations
GBN	Ground Borne Noise
GBV	Ground Borne Vibration
LPP 10	Local Planning Policy 10 Pedestrian Walkway
LPP 29	Local Planning Policy 29 Public Art Private Developer Contribution
LPP 32	Local Planning Policy 32 Exemptions from Development Approval
LPP 37	Local Planning Policy 37 Community Consultation on Planning Proposals
LPP 39	Local Planning Policy 39 Tree Planting and Retention
LPP 39	Local Planning Policy 39 Tree Planting and Retention
LPS	Draft Local Planning Strategy
LPS 1	Local Planning Scheme No. 1
METRONET Act	Railway (METRONET) Amendment Act 2021
METRONET Amendment Bill	Railway (METRONET) Amendment Bill 2022
MNRG	METRONET Noongar Reference Group
OLE	Overhead Line Equipment
OMTID	Office of Major Transport Infrastructure Delivery
OGA	Office of Government Architect
PCA	Planning Control Area
PD Act	Planning and Development Act 2005
PTA	Public Transport Authority
SCP	Town of Victoria Park Strategic Community Plan 2017-2032
SDRP	State Design Review Panel
SPP 5.1	State Planning Policy 5.1 Land use planning in the vicinity of Perth Airport
SPP 5.4	State Planning Policy 5.4 Road and Rail Noise
SPP 7.0	State Planning Policy 7.0 Design of the Built Environment
The City	City of Canning
The Town	Town of Victoria Park
TOD	Transit Orientated Development
VPCLXR	Victoria Park-Canning Level Crossing Removal project
WAPC	Western Australian Planning Commission

1. Introduction

This report has been prepared by element, as the nominated planning consultant for ALUA, in support of an application for early works associated with the elevated rail component of the VPCLXR project within the Town of Victoria Park (the Town).

This report has been prepared to provide:

- an overview of the VPCLXR project;
- an overview and explanation of the works that form part of this development application, requiring approval from the Western Australian Planning Commission (WAPC);
- an overview and explanation of the works that are exempt from the requirement for planning approval;
- an overview of the proposed approach to future development applications that will be required for the other components of the VPCLXR project that are not included in this development application (i.e. new train stations, new station public realm design, bus interchanges, Principal Shared Paths (PSP), public car parking facilities (park and ride facilities) and the broader public spaces, landscaped areas and facilities under the viaduct);
- an overview of the subject site¹ for the purposes of this development application;
- an assessment of the proposal against relevant planning requirements; and
- an examination of the planning merits of the proposal.

This report is accompanied by detailed development plans and elevations as well as supporting technical reports, detailed as follows:

- Appendix A – Subject Site Details
- Appendix B – Requirements for Planning Approval
- Appendix C – Detailed Planning Assessment
- Appendix D – Certificates of Title
- Appendix E – PCA Boundary
- Appendix F – Civil Structures and Viaduct Drawings (Plans, Elevations, Typical Sections)
- Appendix G - Retaining Walls and Abutment Plans (Plans, Elevations, Typical Sections)
- Appendix H – Work Zones and Tree Management Plans
- Appendix I – Construction Management Plan
- Appendix J – Operational Noise and Vibration Report
- Appendix K – Services Alteration and Relocation Concept Plans
- Appendix L – Basic Summary of Records

The overall VPCLXR project location and particular location of the elevated rail infrastructure is shown in Figures 5 to 8.

Further information in relation to the site details relevant to the development application have been included at Appendix A.

Refer to Appendix A – Subject Site Details

Refer to Figure 5 – Indicative extent of full VPCLXR project (extending through both the Town of Victoria Park and the City of Canning)

Refer to Figure 6 – Location Plan - extent of VPCLRX Project within the Town of Victoria Park

Refer to Figure 7 – Aerial Plan – extent of VPCLRX Project within the Town of Victoria Park

Refer to Figure 8 – Site Plan – extent of VPCLRX Project within the Town of Victoria Park

¹ The subject site for the purposes of this application is the area within which the works require planning approval, namely within both the PCA and the designated Railways Reservation.



Figure 5. Indicative extent of full VPCLXR project (extending through both the Town of Victoria Park and the City of Cannington)

Armadale Line Upgrade Project

Victoria Park Early Works Development Application No. 1 – Viaduct Construction and Enabling Works

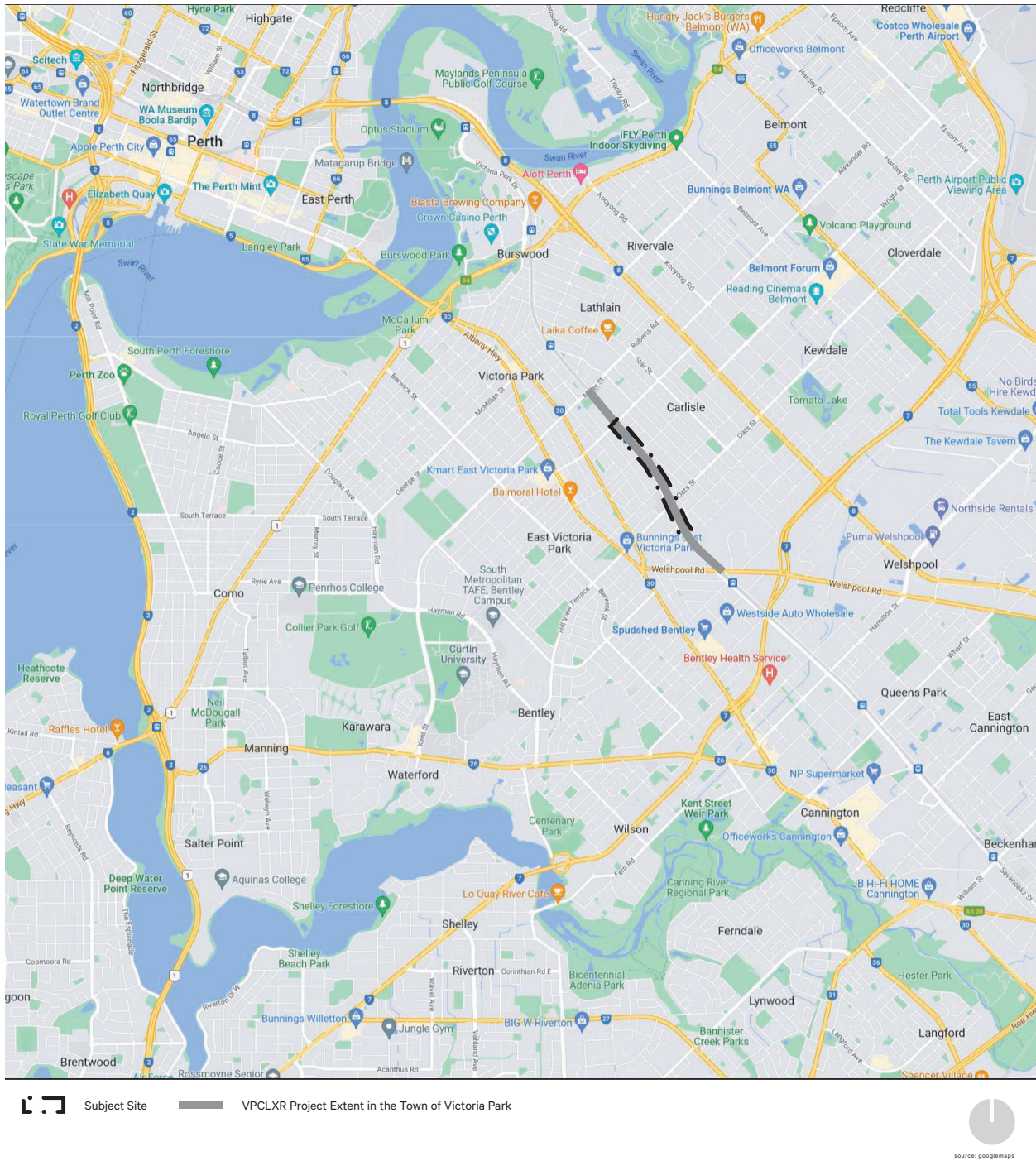

Figure 6. Location Plan - extent of VPCLRX Project within the Town of Victoria Park



Figure 7. Aerial Plan – extent of VPCLRX Project within the Town of Victoria Park

Armada Line Upgrade Project

Victoria Park Early Works Development Application No. 1 – Viaduct Construction and Enabling Works

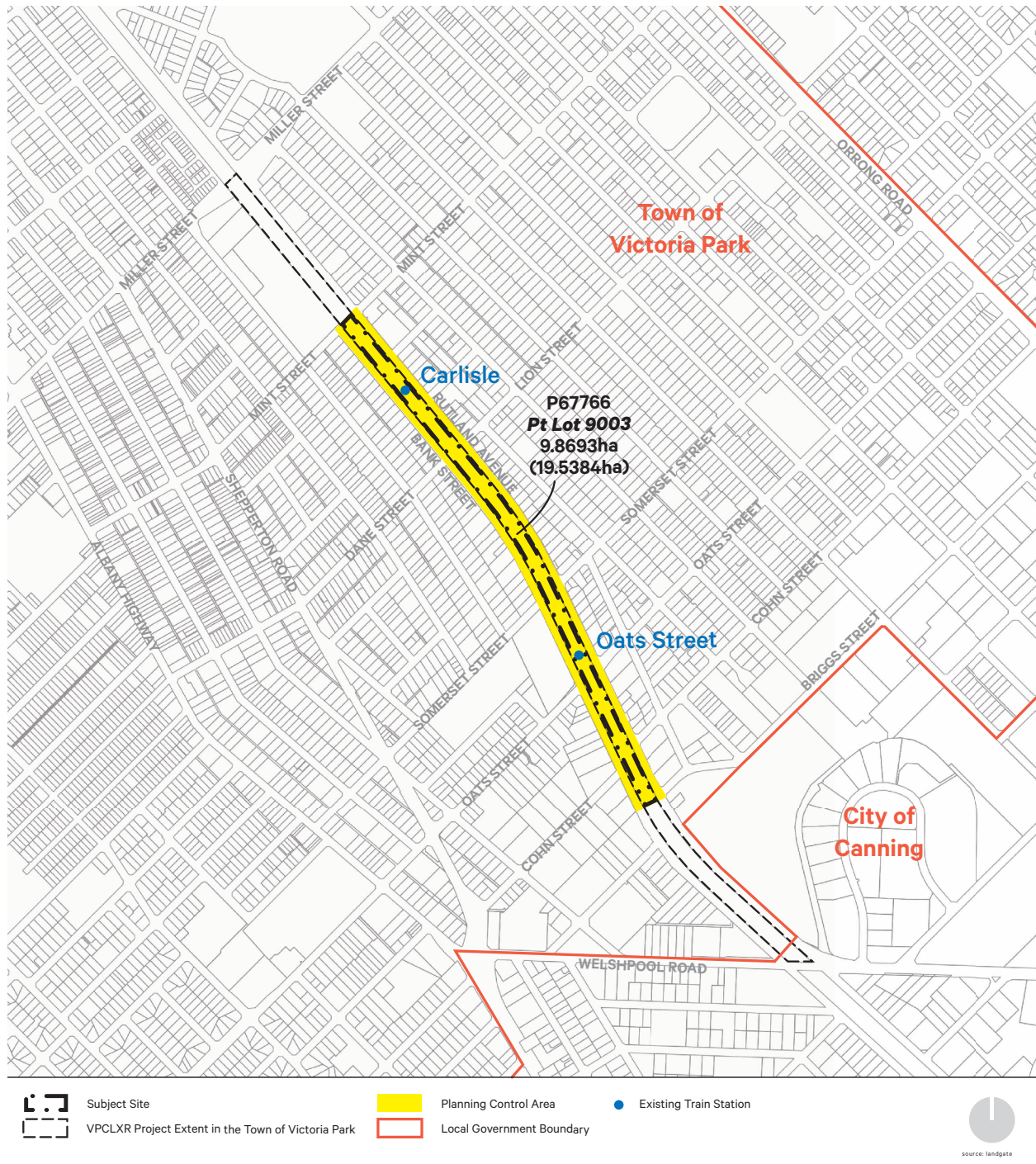

Figure 8. Site Plan – extent of VPCLRX Project within the Town of Victoria Park

This application seeks approval for the following VPCLXR project components only:

- Early works and site establishment works (including removal of vegetation, crane pads, and gantry work zones).
- Piling for the viaduct.
- Viaduct piers and structure.
- Operational railway infrastructure / works (i.e. rail track, maintenance tracks, signalling infrastructure, OLE masts, overhead rail lines and infrastructure etc).
- Alteration or relocation of existing services (including overhead power lines, drainage, water and gas infrastructure) where these are located within the rail corridor;
- Electricity works for the railway.
- Temporary work zones within the rail corridor.
- Demolition of existing train stations (including Welshpool Train Station).

These components are specifically separated from the full suite of project components to allow for a project enabling early works package to be delivered in isolation of the new train stations, ground level station precincts and public realm encompassing new public spaces and facilities. These key structural works are critical to the overall timely implementation of the project, which aims to reduce the overall construction timeframe, rail shut down period and associated impacts to the local community as a consequence of the project delivery.

This report has been prepared to provide an overview of the subject site and the proposed project works, as well as an assessment against relevant planning requirements and an examination of the planning justifications for the proposal. The application is also accompanied by supporting plans and technical documents, as discussed throughout this report.

Refer to Appendix F – Civil Structures and Viaduct Drawings (Plans, Elevations, Typical Sections)

Refer to Appendix G - Retaining Walls and Abutment Plans (Plans, Elevations, Typical Sections)

Refer to Appendix H – Work Zones and Tree Management Plans

Refer to Appendix K – Services Alteration and Relocation Concept Plans

Armada Line Upgrade Project

Victoria Park Early Works Development Application No. 1 – Viaduct Construction and Enabling Works

1.1 Project Overview

The VPCLXR project will deliver an elevated rail line and rail stations for a section of the Armadale Rail Line commencing to the south east of the existing Miller Street overpass in Victoria Park and extending to the north west of the existing Gerard Street overpass in Cannington. The project will also create new and connected open spaces, parkland and community infrastructure that will act as a catalyst for positive social interaction and urban renewal within the surrounding area.

In August 2022 it was announced that there would be a further section of elevated rail added to the scope of the project, extending the project into the City of Gosnells, to include a new Beckenham Train Station and the removal of the William Street level crossing. Given the late inclusion of this section of the rail line in the VPCLXR project, the development applications for the part of the project that is included in the City of Gosnells will follow at a later point in time.

The project is designed to improve public transport safety, create new and versatile public spaces for the community and reduce traffic congestion. The key works include:

- Three sections of new elevated rail line, or viaduct, comprising piers, pier headstock and ‘U trough/s’.
- The removal of six (6) existing level crossings at Mint Street, Oats Street, Welshpool Road, Hamilton Street, Wharf Street and William Street.
- The redevelopment five (5) new, modern elevated train stations at Carlisle, Oats Street, Queens Park, Cannington and Beckenham.
- The removal of the existing Welshpool Train Station.
- New station precincts at ground plane level around each of the new stations including bus facilities, patron parking and landscaping.
- New ground level public realm works between station precincts incorporating public spaces and facilities.

Refer to Figure 9 – Concept diagram of extent of VPCLXR Project

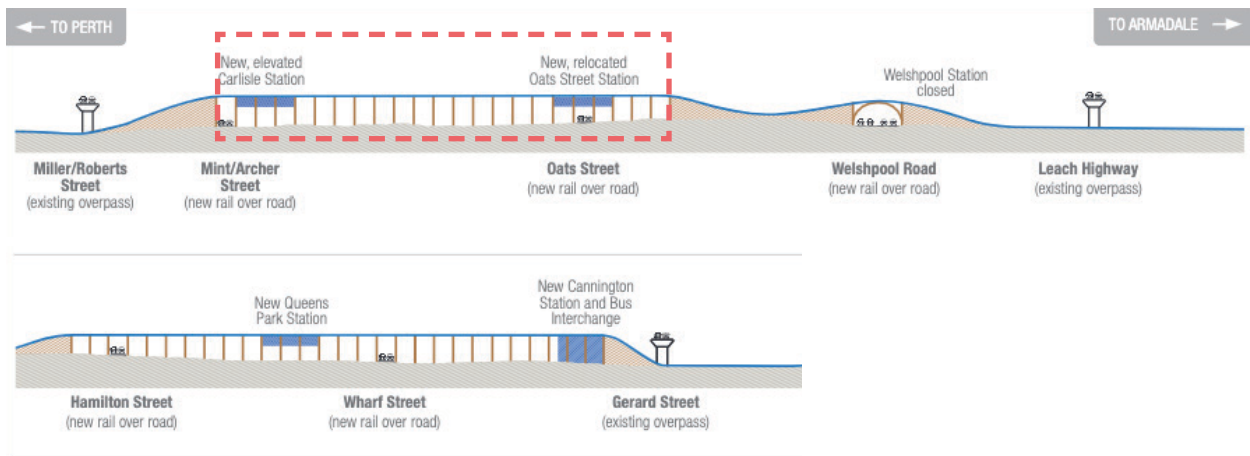

Figure 9. Concept diagram of extent of VPCLXR Project, with the extent of the viaduct that is the subject of this development application shown highlighted in red outline (note that new stations will be subject to future separate development applications) (source: METRONET 2022)

This development application relates to the early works components of the VPCLXR project that are located within the Town of Victoria Park. A separate simultaneous development application has been prepared and submitted for the early works and viaduct structure components of the VPCLXR project that are occurring within the City of Canning. ALUA, in consultation with the community and other key stakeholders are currently exploring new train station and public realm specific design considerations, which will be included in separate future development applications.

The following diagram explains the structure and separation of the development applications that will inform and obtain the necessary planning approvals for specific components of the VPCLXR project, which are described in further detail within Section 5 of this report. At this point in time, given the relatively recent inclusion of the Beckenham station and City of Gosnells section of the project in the VPCLXR project, it has not yet been determined how the City of Gosnells development applications will be structure or when they will be lodged.

Refer to Figure 10 – Anticipated Development Application Staging

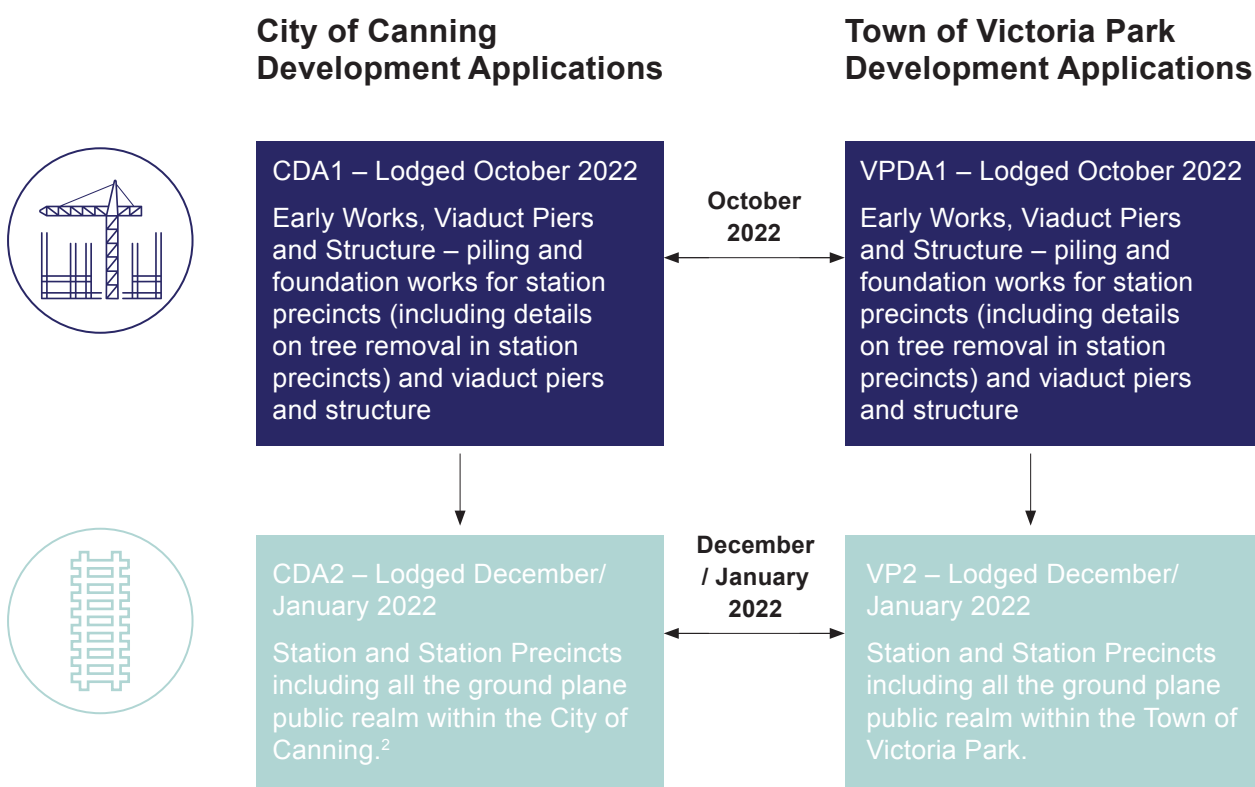

Figure 10. Anticipated Development Application Staging

1.2 Project Team

Table 1: Consultant List

Consortium (providing engineering and construction expertise and delivering the project)	Armadale Line Upgrade Alliance <ul style="list-style-type: none"> • Acciona Construction Australia Pty Ltd; • BMD Constructions Pty Ltd; • WSP Australia Pty Ltd; and • AECOM Australia Pty Ltd.
Planning Consultant	element
Architect and Landscape Architect	Hassell

1.3 Planning Approval Pathway

The planning approval process for the VPCLXR project is controlled by several key legislative and regulatory provisions, as summarised below:

- *The Planning and Development Act 2005* (PD Act), which provides exemptions for ‘public works’ from the need to obtain planning approval for such developments under the applicable local government planning framework (i.e. under a local government local planning scheme);
- The *Metropolitan Region Scheme* (MRS), which exempts all work for, or in connection with a railway that are located inside a designated railways reservations from the need for planning approval, other than for the construction or alteration of a railway station, or any related car parks, public transport interchange facilities or associated means of pedestrian or vehicular access;
- Declaration of Planning Control Area No.165 (PCA) under Part 7 of the PD Act. A PCA is an enabling planning mechanism that requires that all development within the PCA is to be considered and determined by the WAPC; and
- *The Railway (METRONET) Act 2018* (METRONET Act) includes the VPCLXR project, which means that certain METRONET works are exempt from the need to obtain planning approval where these METRONET works are situated outside of the designated MRS Railways Reservation.

The relevant legislative framework that applies to the VPCLXR project has been described in more detail at Appendix B.

Refer to Appendix B – Requirements for Planning Approval

All VPCLXR project works that form part of this application are located within both the railways reservation and the PCA and therefore require approval from the WAPC. Further information on the proposed works components and whether or not these require planning approval is provided in Section 5 of this report.

1.4 Related Approval Processes

Figure 11 below illustrates the typical assessment process which will be followed for each development application, including required public consultation and notification requirements.

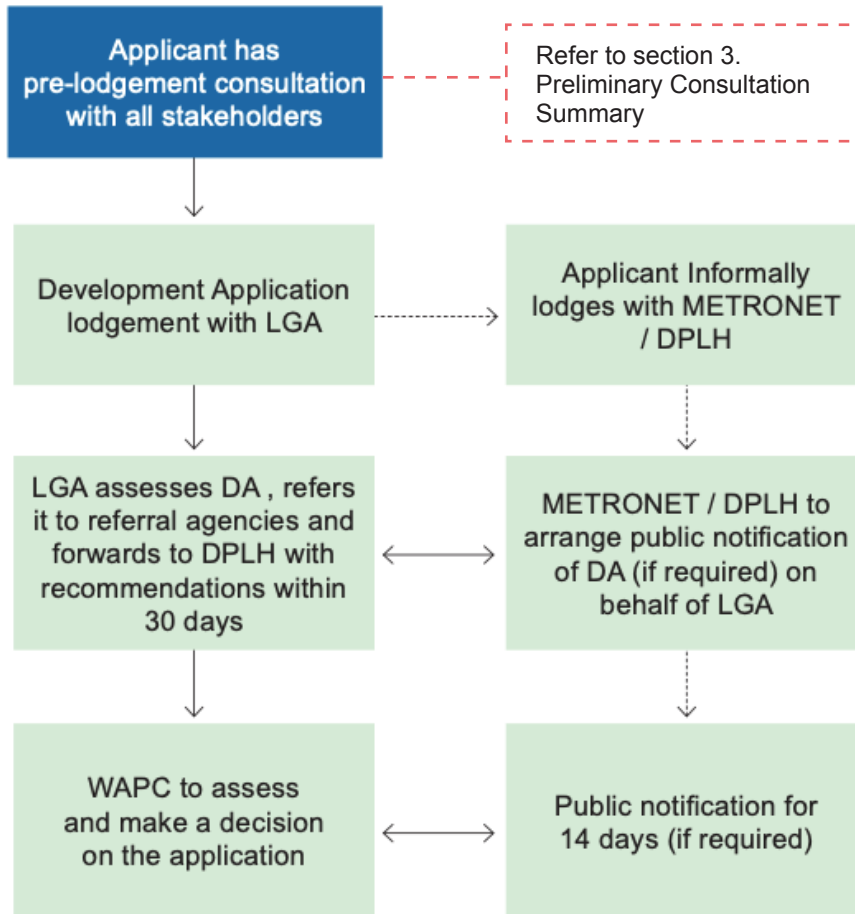

Figure 11. Typical development application assessment flow chart

As demonstrated in Figure 11, the applications will be referred to a number of State Government Agencies, who are key stakeholders for the VPCLXR project. The referral agencies include but are not limited to:

- METRONET;
- Office of the Government Architect;
- Public Transport Authority;
- Main Roads Western Australia; and
- Department of Water and Environmental Regulation.

These stakeholders will be given an opportunity to review the applications and provide comments and recommendations to the WAPC that will be used to inform the assessment of the proposed development and to set any associated conditions of approval.

2. Project Background

The VPCLXR project is Perth's first major elevated rail line designed to improve public transport safety, create new and versatile public open space for the community and reduce traffic congestion through the removal of level crossings.

Level crossings on the Armadale Rail Line have been causing significant problems, including vehicle and pedestrian safety issues and traffic congestion and delays. The removal of the level crossings will address the objectives of the METRONET rail program by:

- Supporting sustainable, economic growth in Perth;
- Improving connectivity between communities and businesses; and
- Increasing accessible travel and lifestyle options.

The VPCLXR project proposes the removal of six level crossings along the Armadale Rail Line including; the Mint Street, Oats Street, Welshpool Road, Hamilton Street, Wharf Street and William Street level crossings. The new elevated rail line or viaduct will allow the removal of the level crossings by removing the movement barrier associated with the existing at grade rail line. As a consequence of the elevated rail line all existing at grade train stations along this part of the line will need to be removed and replaced with new elevated train stations and associated public parking, bus interchange and public realm treatments, including new public spaces and facilities.

It was determined very early in the planning phases to make the VPCLXR project an elevated rail line, as opposed to putting the rail line underground. In this regard the extensive early planning undertaken by the State Government determined that an underground rail solution was an unfeasible option, due to the availability of land for the project within the existing MRS Railways Reservation, the cost differential (both the up front capital cost as well as the ongoing operational cost) for sinking the rail rather than elevating it and, given the success of similar elevated rail projects in the Eastern States.

The new elevated rail line will create a major opportunity for positive and desirable land use changes that generate:

- Increased recreational opportunities (active and passive) and social interaction from new public spaces and facilities at ground level along the length of the viaduct;
- Improved amenity for the surrounding areas from new public open space and an upgraded public realm;
- Reduced urban heat island effect through increasing vegetation and tree canopy along the length of the project;
- Improved passive surveillance and safety as a result of designing the new infrastructure and public realm in a manner that is consistent with the principles of Crime Prevention Through Environmental Design (CPTED);
- Opportunities to increase public use and patronage of the rail line through the provision of new train stations, bus interchanges and parking facilities;
- Opportunities to support enhanced community interaction and activity through the delivery of event spaces within the public realm (station forecourts and appropriately configured public spaces) that support 'pop up' events and markets (or similar); and
- Opportunities to leverage new local development opportunities from the significant investment in public infrastructure and improvements in the local environment.

The project has been designated by the WA Government as a 'project under acceleration' as part of its commitment to economic recovery in the wake of the COVID-19 pandemic and is outlined in the State Government's WA Recovery Plan.

Removing the level crossings will allow road traffic to move more safely and efficiently by travelling beneath the rail line without stopping or queueing for boom-gate closures. The area underneath the raised rail line will be transformed into public open space and will facilitate active transport connectivity across the project area and beyond. The improvements to the rail line and the new train stations will also be able to service the longer trains that the PTA plan to introduce as part of the Network Train Operating Plan (2018).

Whilst most of the existing stations are to be rebuilt as elevated stations, the Welshpool Station is to be removed from the system due to its low patronage numbers.

The project is to be principally constructed during an 18 month shut down period during which the rail line will be closed and there will be replacement bus services in operation. METRONET has publicly acknowledged that this shutdown process will be disruptive to the community however it was determined as the most appropriate option to deliver the new rail line quickly and safely. Temporary bus stops and bus interchanges will also be established during this period to support the replacement bus services that are operational during this time and until the new permanent bus stops and interchanges come on line as part of the VPCLXR project. Importantly, the recent shut down of the Mandurah line in January 2022 has provided Transperth with a number of valuable learnings that will help to ensure that when the Armadale line is shut the replacement bus network will provide a suitable alternative.

3. Preliminary Consultation Summary

3.1 Pre-Lodgement Agency and Community Consultation

3.1.1 Community Consultation

METRONET commenced consultation on the VPCLXR project with the community in 2020 with advertisements relating to the project released to the public as early as June 2020 through online mediums and letterbox drops.

Early engagement with the local community included in-person briefings before moving online for a few months due to the restrictions brought on by the COVID-19 pandemic. A summary of the communication and engagement statistics are listed below:

- 2020: A total of 44 sessions/online advertisements reaching approximately 110,347 individuals;
- 2021: A total of 28 sessions/online advertisements reaching approximately 68,941 individuals; and
- 2022: One (1) letterbox drop reaching 60 individuals.

The information provided to the public included updates on the project, requests for input, services notices and general information relating to the project.

Two Community Reference Groups (CRGs) were established to help inform the design concepts for the VPCLXR project. The Oat Street CRG covers the works proposed to Oats Street, Mint Street and Welshpool Road and the Wharf Street Community Reference Group (Wharf Street CRG) covers Wharf, Hamilton and William Streets. The groups are each made up of 10 residents, business owners and community group representatives. The works proposed as part of this report were reviewed by the Wharf Street CRG.

Four (4) meetings were held with the Wharf Street CRG across 2020 and 2021. These CRGs were facilitated by METRONET prior to ALUA's involvement in the project. The CRG members reviewed early design concepts to decide the best locations for public spaces, facilities and access points.

It is noted that these meetings primarily discussed the desired public realm outcomes associated with the project, which will be addressed in future separate development applications. Notwithstanding, key feedback from the early engagement on the project viaduct was focussed on:

- Potential noise impacts from an elevated rail structure;
- The visual impact of an elevated rail structure;
- Construction impacts;
- Opportunities recognised to ease congestion, save time and increase safety;
- Opportunities identified for new public spaces and revitalisation, increased shelter and improved accessibility across the rail corridor.

3.1.2 Stakeholder Consultation

Since being awarded the contract for the VPCLXR project ALUA has engaged with a number of key stakeholders that are relevant to the project. These have included:

- METRONET;
- Town of Victoria Park;
- Office of the Government Architect;
- State Design Review Panel;
- Public Transport Authority;
- City of Canning;
- Department of Planning, Lands and Heritage Assessment Teams;
- City of Gosnells;
- Community Reference Groups;
- METRONET Noongar Reference Group;
- Main Roads;
- Western Power;
- Other relevant servicing agencies (i.e. ATCO gas).

4. Site Analysis and Design Response

4.1 Design Principles

State Planning Policy 7.0 – Design of the Built Environment (SPP 7.0) requires that new development proposals and planning frameworks address design principles within the policy which have been identified to promote good design outcomes. A design principles response prepared by Hassell addressing how the proposed viaduct design responds to the SPP 7.0 design principles is provided in Table 2 below.

Table 2 – Assessment Against SPP 7.0

Principle	Response
Context and Character	
<i>Good design responds to and enhances the distinctive characteristics of a local area, contributing to a sense of place.</i>	<p>The overarching project design principles reflect Metronet’s initial approach of “collective”, “connected” and “specific”. This approach set out the strategy of “collective” elements which are consistent across the length of the project, “connected” elements which respond to the two separate areas of the Oats St group and Wharf St group and “specific” elements which respond to each individual station precinct.</p> <p>ALUA worked with our Cultural advisors and collaborators, Barry McGuire and Carol Innes to establish an overarching cultural narrative for project and to develop integrated design concepts.</p> <p>The design approach for the viaduct, piers and screening leveraged the “collective” to provide a consistent line wide response, whilst the form and character responds to the cultural narrative for the energy of country and safe movement from place to place.</p>
Landscape quality	
<i>Good design recognises that together landscape and buildings operate as an integrated and sustainable system, within a broader ecological context.</i>	<p>Consideration has been given to the viaduct design to ensure it will positively impact the surrounding public realm and landscape quality. The location and design of the piers has been carefully considered to minimise their impact on the future public realm in terms of both footprint and sightlines.</p> <p>The integrated drainage solution within the piers allows direct infiltration to the areas beneath the viaduct.</p> <p>Additionally, the ground profile beneath the viaduct has been profiled to capture run off and minimise rain shadow effect.</p>
Built form and scale	
<i>Good design ensures that the massing and height of development is appropriate to its setting and successfully negotiates between existing built form and the intended future character of the local area.</i>	<p>The design of the viaduct comprises three main elements; the viaduct beams, piers and crossheads and the walkway screens.</p> <p>The viaduct beams are nominally 30 metres in length (each span) and are optimised for engineering efficiency and construction. The profile is consistent through the project maintaining a simple form.</p> <p>The piers and cross heads have been sculpted with the tapered form visually reducing the mass. The faceted faces profile a finer scale and will respond differently with light.</p> <p>The walkway screen is a continuous ribbon along the viaduct, acting as both a walkway balustrade and a screen for the electrical and communications cable containment. The screen will have a profiled form and perforated pattern to provide visual amenity both at a distance and also when viewed from within the public realm.</p>

Principle	Response
Functionality and build quality	
<i>Good design meets the needs of users efficiently and effectively, balancing functional requirements to perform well and deliver optimum benefit over the full lifecycle.</i>	<p>The viaduct and piers are highly functional elements, which give consideration to the construction process, rapid production and repeatability. The form of each considers engineering efficiency and has been developed to ensure the quality will be maintained through the manufacturing process.</p> <p>The piers and headstock will be painted to ensure maintainability and the rectification of graffiti.</p> <p>The viaduct beams will remain off form grey concrete (class 2 finish) to minimise ongoing maintenance. The viaduct comprises two 'L' beam elements with a concrete stitch element between. This element will be constructed with a permanent steel formwork with hot dipped galvanised finish.</p>
Sustainability	
<i>Good design optimises the sustainability of the built environment, delivering positive environmental, social and economic outcomes.</i>	<p>Through the development of the design, the viaduct was optimised to reduce the overall cross-sectional width by approximately 2m. This rationalisation provides significant reduction to the concrete usage.</p> <p>Additionally, the fabrication method of repeated precast elements will minimise wastage.</p>
Amenity	
<i>Good design provides successful places that offer a variety of uses and activities while optimising internal and external amenity for occupants, visitors and neighbours, providing environments that are comfortable, productive and healthy.</i>	<p>The viaduct is utilised throughout the public realm to provide shade and rain protection for public spaces, carparking and drop off areas and also the bus interchange at Oats Street Stations.</p>
Legibility	
<i>Good design results in buildings and places that are legible, with clear connections and easily identifiable elements to help people find their way around.</i>	<p>The design approach to the viaduct and associated elements focusses on visual consistency, the simplicity of form and rhythm of repetition.</p> <p>With the viaduct screening it is intended for the perforation pattern for provide distinct expression at key locations, such as Stations and road crossings. The pattern is being developed with our Noongar Artist, Barry McGuire and the Architect</p> <p>The piers will be painted, with the design intent to respond to the station colour strategy and the overall landscape corridor however this colour palate is still in development.</p>
Safety	
<i>Good design optimises safety and security, minimising the risk of personal harm and supporting safe behaviour and use.</i>	<p>Throughout the corridor, safety is a key consideration. The design team have focussed on providing clear, open sightlines in and around the viaduct. The vertical clearance to the underside of the viaduct is generally 5-6m with a minimum clearance of 3m at the embankment abutments. Pier location and sizing has accounted for the need to maximise visibility with clear sight lines along shared paths and roads as well as the need to eliminate any entrapment spots or locations of concealment.</p> <p>The balustrade screen also provide safety for passengers using the walkway to egress in emergency and also for rail maintenance workers.</p>
Community	
<i>Good design responds to local community needs as well as the wider social context, providing environments that support a diverse range of people and facilitate social interaction.</i>	<p>The key benefit of the elevated rail solution is the ability to reconnect the community across the previously inaccessible rail corridor. The viaduct design optimises the space required for the rail infrastructure and provides generous space under and adjacent for public use and landscaping.</p> <p>In developing the design, consideration has been given to locating piers such that they enable the future connection of existing tertiary roads along the corridor.</p>

Principle	Response
Aesthetics	
<i>Good design is the product of a skilled, judicious design process that results in attractive and inviting buildings and places that engage the senses.</i>	<p>In addition to the design response noted above with respect to the refinement of the form and consideration of finishes, our key aesthetic principle is to conceal all services. This has been an issue for other precedent projects such as the Melbourne Level Crossing Removal projects and a key lesson learnt.</p> <p>We have contained all viaduct drainage within the piers, with the pipework taken beneath ground level and then relieved into the landscape.</p> <p>All electrical and communications services are reticulated up to viaduct level at each Station and along the rail embankments (trackside).</p> <p>The rail infrastructure, such as masts for the overhead line, is generally located centrally along the viaduct. Signalling poles will be located behind the walkway screen with minor projections 'blisters' required to maintain the walkway around the outside of these elements.</p>

4.2 State Design Review Panel Engagement

The State Design Review Panel (SDRP) provides independent, expert advice to Government agencies, decision makers and proponents regarding the design quality of a range of project types.

The VPCLXR project is a significant public works project and is eligible for SDRP review. In this regard ALUA has met with the Office of the Government Architect (OGA) to develop a design review framework that has regard to the overall project objectives, costings and critical timings.

The proposed design review framework agreed with the OGA for this project broadly comprises three (3) separate design reviews with each of these focusing on specific project elements as outlined below

1. Initial SDRP No. 1 – Previously completed in METRONET Project Definition Plan phase of the project.
2. Interim SDRP No. 2 – Recently completed in June 2022. This SDRP meeting covered the whole of the project area and scope, including critical infrastructure components (such as the viaduct structures), elements that are exempt from requiring planning approval and initial conceptual ground level public realm elements, built form and character analysis of stations and station precincts.
3. SDRP No. 3 – Recently completed in August 2022. This SDRP will focussed on the built form of all new train stations and associated station precincts.

Feedback received during SDRP No. 3 is currently being considered by ALUA in consultation with key stakeholders. The SDRP reviews held to date have predominantly focussed on the design approach to the new train stations and public realm however the design of the piers, pier headstock and 'U' troughs, which form part of the viaduct, have been included in the scope of the review process.

Whilst principally enabling engineering structures that need to meet specific technical criteria, Hassell has been closely involved in reviewing and designing these structures to ensure that an architectural design approach has been applied to their form, design and placement. The SDRP and OGA have also been consulted on the design of the viaduct structure.

It is noted that the details of architectural screens and/or paint finishes that will form part of the viaduct design are not resolved at this stage. It is proposed that the future provision of these details will be subject to relevant conditions on the approval. It is reasonably expected that any such conditions will involve consultation with both the OGA and the relevant Local Government Authority. In this case the Town.

An assessment of the structure against the design principles of *State Planning Policy 7.0: Design of the Built Environment* is included at Section 4.1 above demonstrating the design approach applied to the proposed viaduct structure.

5. Description of Proposed Development

5.1 Development Overview

This development application relates to early works and the key enabling infrastructure component of the VPCLXR project, being the viaduct, that is required to facilitate the overall construction of the project in a timely and least disruptive manner.

The early site establishment and services relocation works are considered to not be materially significant to the intended outcome of the overall development and are generally required to facilitate the construction of the viaduct only. All new station designs, station precinct design considerations (including new public parking (park and ride facilities), new bus interchanges and the station public realm) along with the broader public realm, including public spaces and facilities that are to be delivered between stations, will be the subject of separate future development applications.

In general terms, the works proposed as part of this application include the piling and foundation works for the viaduct, the development of the viaduct piers, pier headstock and ‘U’ trough structures along the full length of the VPCLXR project (where these are located within the designated PCA). This includes the piers and pier headstocks and ‘U’ troughs which will run through the future train station and station precinct areas. A summary of the works proposed as part of this application is as follows:

- Early works and site establishment works (including removal of vegetation, crane pads, and gantry work zones).
- Piling for the viaduct.
- Viaduct piers and structure.
- Operational railway infrastructure / works (i.e. rail track, maintenance tracks, signalling infrastructure, OLE masts, overhead rail lines and infrastructure etc).
- Alteration or relocation of existing services (including overhead power lines, drainage, water and gas infrastructure) where these are located within the rail corridor and relocation of PTA’s Main Cable Route (MCR).
- Electricity works for the railway.
- Temporary work zones within the rail corridor.
- Demolition of existing train stations.

This development application seeks approval only for the works that are located both within the PCA and within the rail corridor.

METRONET rail related works that are located outside of the rail corridor and within the PCA2 are exempt from requiring planning approval under the METRONET Act. METRONET works that are located outside of the PCA are also exempt from requiring planning approval (refer to Section 5.2 for further explanation) under the METRONET Act.

Refer to Appendix E – PCA Boundary

5.2 Extent of Works and Exempt Works

Table 3 below provides an overview of the works forming part of the VPCLXR project and identifies whether particular works are exempt from the requirement to obtain planning approval under the proposed amendments to the METRONET Act or require planning approval from the WAPC under the designated PCA that is in place.

It is important to note that project works will not be commencing until after the METRONET Act amendments take effect, thus ensuring that the exemptions from the requirement for planning approval for METRONET works are in effect and apply at the time of commencement.

Table 3: Summary of Works and Approval Requirement and Exemptions

	METRONET works³ - as defined in Railway (METRONET) Act 2018	METRONET station works:
		<ul style="list-style-type: none"> • railway stations • related car parks • public transport interchange facilities • means of pedestrian or vehicular access to station • public realm (within the PCA)
Works located: • Within PCA, and • Within the MRS railways reservation	WAPC approval required for all works (this application)	WAPC approval required for all works (will be subject to separate future development applications)
Works located: • Within PCA; and • Outside the MRS railways reservation	Exempt	WAPC approval required for all works (will be subject to separate future development applications)
Works located: • Outside PCA; and • Outside the MRS railways reservation	Exempt	N/A – there are no METRONET Station works proposed outside of the PCA
Works located: • Outside PCA; and • Within the MRS railways reservation	Exempt	N/A – there are no METRONET Station works proposed outside of the PCA

Exempt works which will not need planning approval on the basis that they are METRONET works and are located outside both the PCA and the rail corridor⁴ include:

- Retaining walls and embankments along the rail corridor where these are supporting the change in level of the existing rail works/line up to the new viaduct.
- Noise walls adjacent to the embankments (which are outside of the PCA).
- Temporary bus stands (shelters and bins) to be used during the required rail line shut down.
- Temporary bus interchanges to be used during the required rail line shut down.
- Temporary laydown / storage areas required to support construction.
- Temporary car parking areas to support construction.
- Rail line turnbacks.

³ METRONET works means works for the purpose of, or in connection with, a METRONET railway but does not include the construction or alteration of a railway station, or any related car parks, public transport interchange facilities or associated means of pedestrian or vehicular access.

⁴ Exempt works also include METRONET Works where these are outside the PCA but within the rail corridor.

For the purposes of transparency and so that the full extent of the proposed project works can be understood, this development application includes plans that illustrate the following works that are exempt from the requirement for planning approval:

- Retaining walls and embankments along the rail corridor where these are supporting the change in level of the existing rail works/line up to the new viaduct.
- Noise walls.

5.3 Early Works

The proposed early works include tree removal where necessary to support the establishment of the gantry crane impact zone (refer to the Tree Management Plans at Appendix H).

It is anticipated that there will also be site offices and laydown areas that may be utilised within the rail corridor work zones, however the final location of these facilities is yet to be finalised.

The early works also include the relocation and alteration of any services that are located within the rail corridor that are impacted by the proposed viaduct works (refer to the services alteration and relocation plans at Appendix K) along with the demolition of the existing stations.

As indicated previously in this report, all new station designs, station precinct design considerations (including new public parking, new bus interchanges and the station public realm) along with the broader public realm, including public spaces and facilities that are to be delivered between stations, will be the subject of separate future development applications.

5.4 Viaduct Piers and Structure

The viaduct piers, headstock and ‘U’ trough structures form the key infrastructure required to elevate the existing rail track, allowing for the removal of the existing level crossings at Mint/Archer Streets and Oats Street. There are four (4) main viaduct segments for the VPCLXR project, with one (1) located within the municipality of the Town, two (2) within municipality of the City and one (1) within the City of Gosnells.

Table 4 below provides the details of the proposed sections of viaduct:

Table 4: Proposed Sections of Viaduct in the Town

Victoria Park
<p>Viaduct 1: The Mint Street-Oats Street Viaduct Mint Street to Oats Street - approx. 1,480 metres in length</p>

The viaducts connect into the existing rail line via abutments located at each end of the viaduct structure. The abutments facilitate an appropriate slope from the viaduct structure into the existing ground level railway line infrastructure. For the most part, the abutments themselves are located outside of the PCA boundaries and do not form part of this application, however in one specific location at the southern end of the PCA that lies within the Town, near Briggs Street, the abutment is located within the PCA boundaries and therefore needs approval. The retaining walls and embankment structures that are located beyond the abutments (and outside of the PCA) are exempt works under the METRONET Act.

Refer Figure 12 - Proposed Extent of the Viaducts

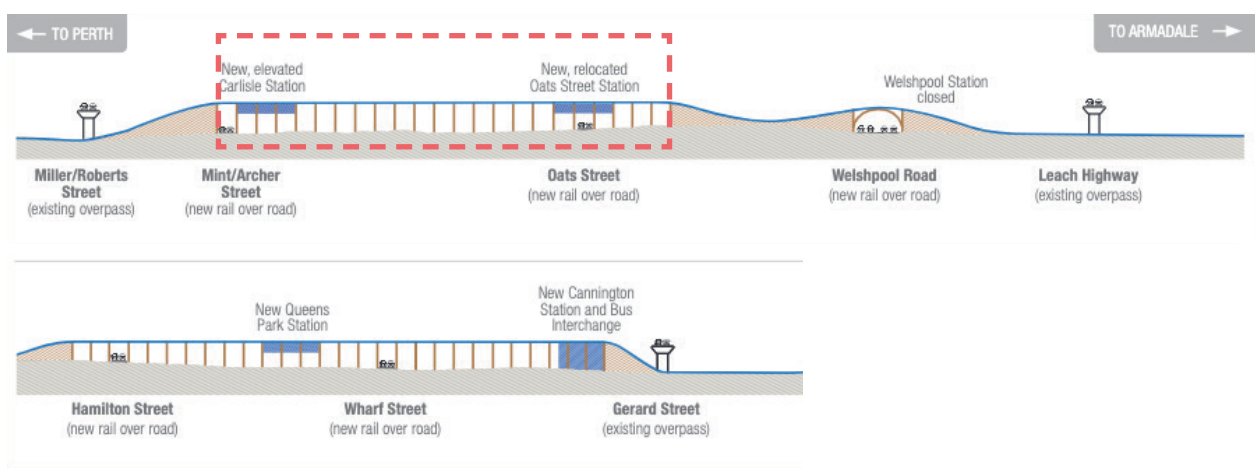

Figure 12. Concept diagram of extent of VPCLXR Project, with the extent of the viaduct that is the subject of this development application shown highlighted in red outline (note that new stations will be subject to future separate development applications) (source: METRONET 2022)

The viaduct will achieve a minimum three (3) metre height clearance at abutments, with specific clearances allowed for at certain locations as follows:

Table 5: Proposed Viaduct Height Clearances in the Town

Victoria Park	Cannington
4.9 metres over Archer Street/Mint Street and Oats Street	<ul style="list-style-type: none"> • 4.9 metres over Hamilton Street and Wharf Street • 5.8 metres over Welshpool Road
<ul style="list-style-type: none"> • 6.0 metres at all stations • 2.5 metres for parking constructed under viaducts 	

The viaduct structure is generally of precast concrete construction. It utilises twin ‘U’ troughs which house the rail line, as shown in Figures 14 to and 17. The superstructure ‘U’ trough consists of two precast L-beams that will be stitched via an in-situ slab to the bottom flange. Detrainment walkways are provided on the outer edge of the flange with a clear width of 1000mm.

An architectural screen will be used to screen the train from view and to provide privacy for residential properties adjacent to the rail corridor. It is noted that the details of architectural screens that will form part of the viaduct design are not resolved at this stage. It is proposed that the future provision of these details will be subject to relevant conditions on the approval.

Armadale Line Upgrade Project

Victoria Park Early Works Development Application No. 1 – Viaduct Construction and Enabling Works

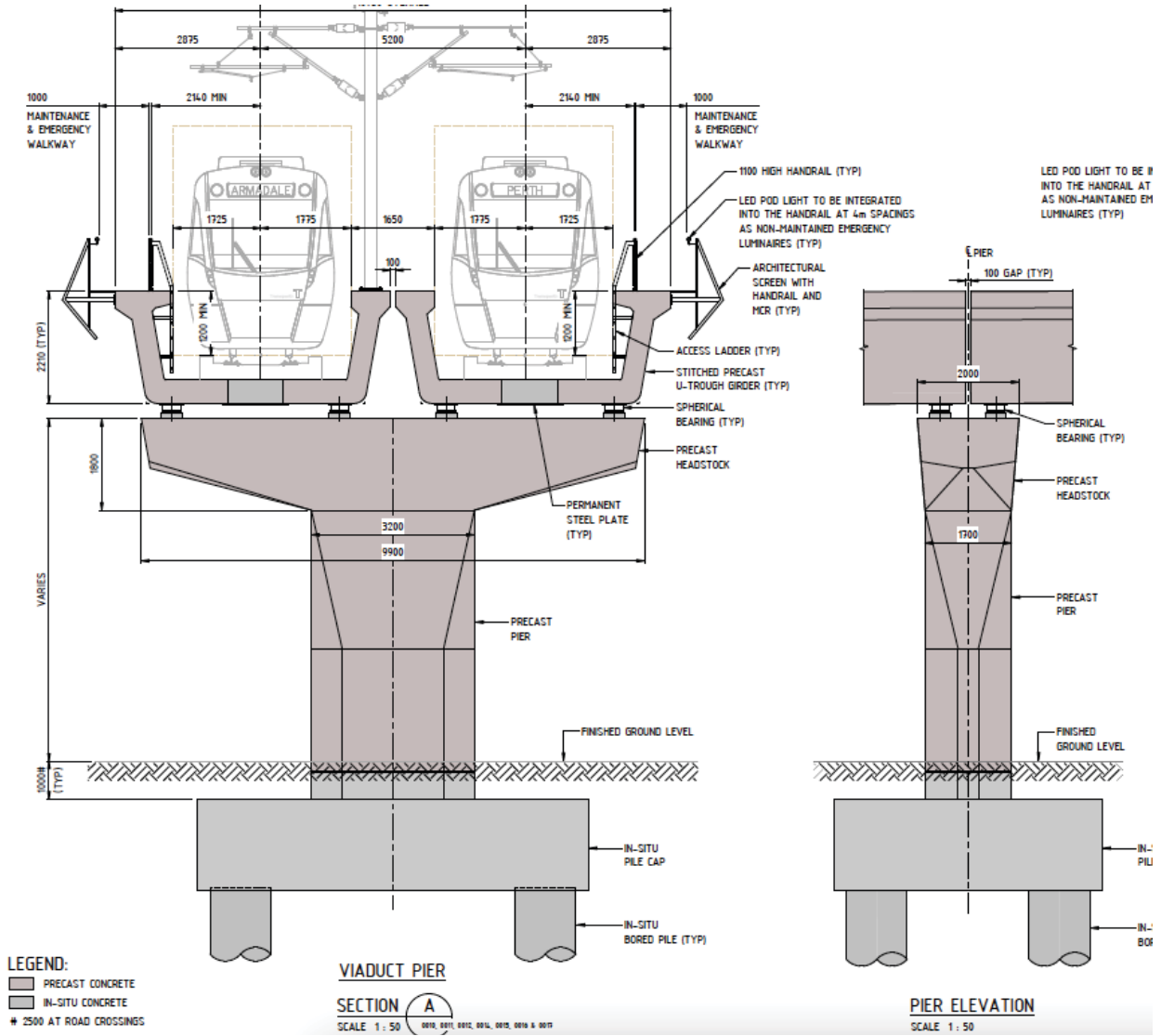

Figure 13. Typical Viaduct Section and Elevation

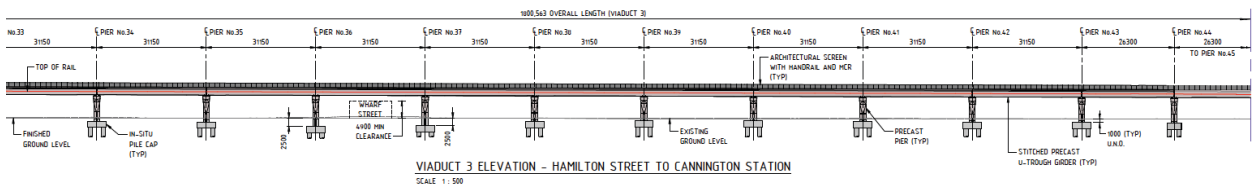

Figure 14. Viaduct Elevation – Mint Street to Oats Street

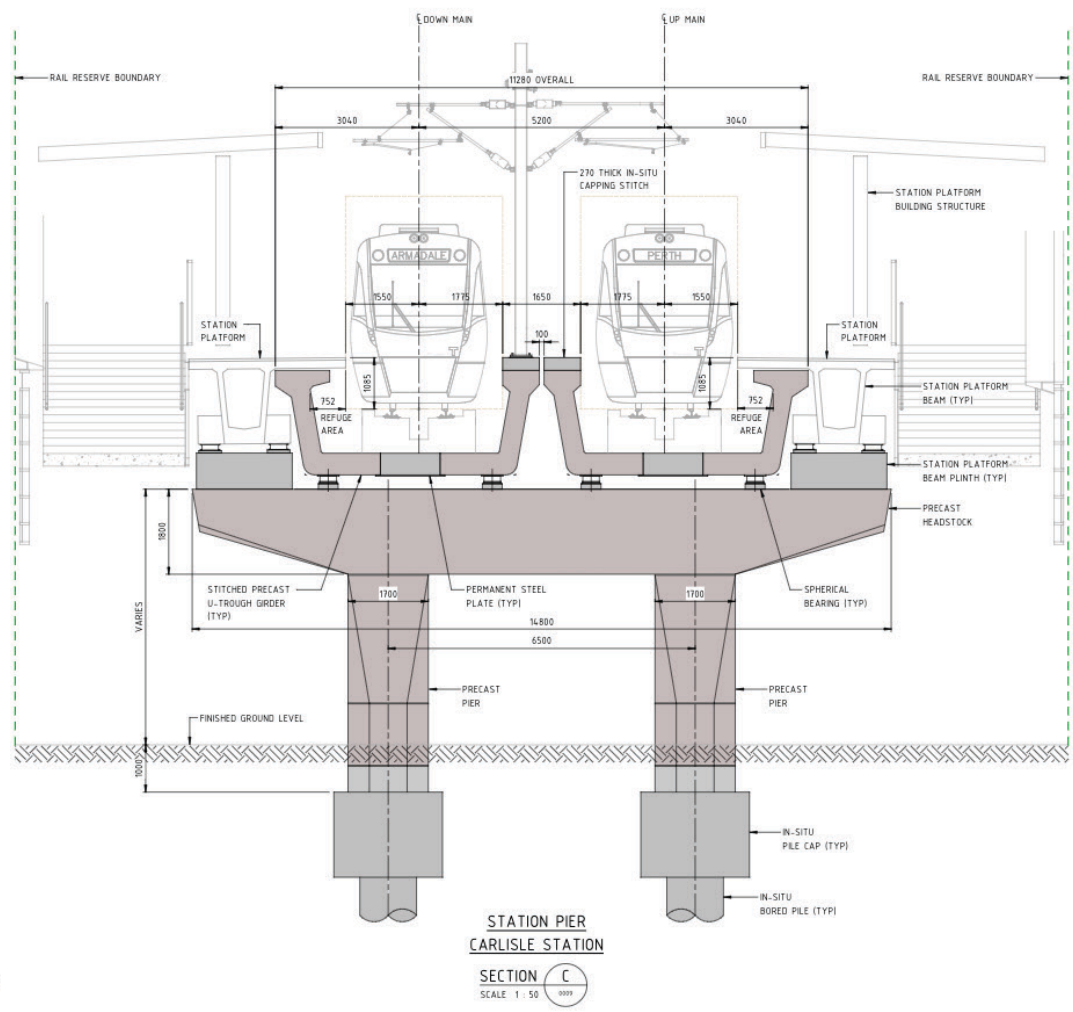

Figure 15. Typical Station Viaduct – Carlisle Station

Armadale Line Upgrade Project

Victoria Park Early Works Development Application No. 1 – Viaduct Construction and Enabling Works

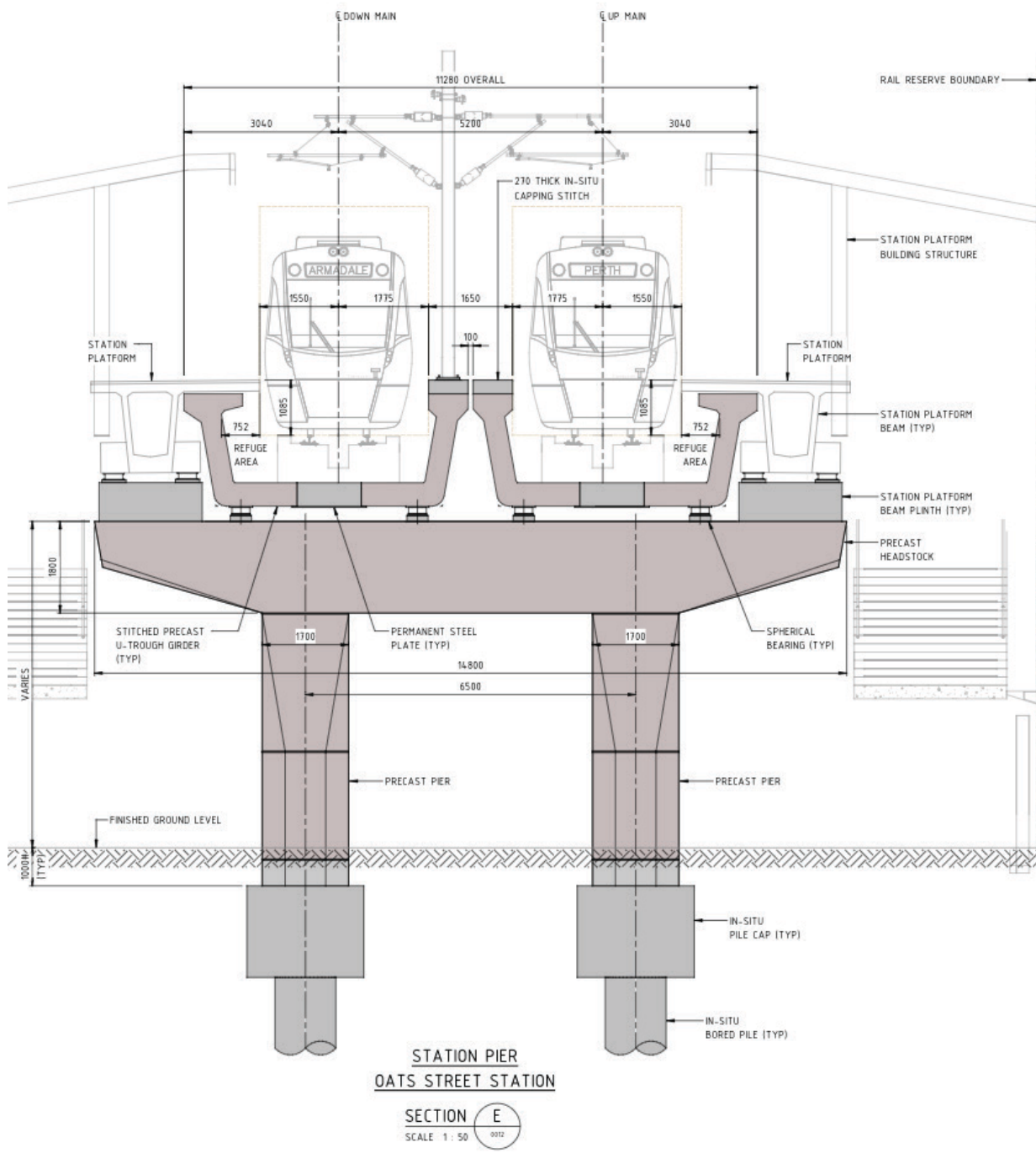

Figure 16. Station Piers - Oats Street Station

5.5 Tree Removal

A Tree Management Plan (TMP) has been prepared by Hassell and is included at Appendix H.

The TMP identifies the trees to be retained as part of the project, trees to be relocated and trees to be removed. It also shows tree protection zones which will be fenced and the construction impact zones associated with gantry crane use, roads, access, laydown and temporary work zones. Notably, only the works that are within the rail corridor and the PCA require planning approval. However given that works impact trees outside of this area and to ensure that the impacts of the project can be understood holistically, the full extent of tree removal/protection/relocation is shown on the TMP included in this development application.

All trees have been assessed by an arborist to determine which should and could be retained having regard to the proposed construction methodology. In this regard, trees within the western side of the rail corridor, which are impacted by the existing Western Power lines are generally compromised and of lesser value than the trees located on the eastern side of the rail line. The Tree Survey and Tree Protection Report are included at Appendix H.

Importantly the TMP is a working drawing. Given that the design processes and construction methodology are still being resolved for this project there may be additional trees that are identified for either removal or retention as the design progresses. It is anticipated that minor changes to the TMP may be able to be managed through the condition clearance process in consultation with the Town and DPLH.

Future, separate development applications for the public realm components of the project (public spaces and facilities) will demonstrate new significant plantings that are proposed to assist in compensating for the proposed loss of existing trees. The approach adopted by the VPCLXR project is that the ultimate canopy within the project area will exceed the existing canopy that needs to be removed to facilitate project construction and delivery.

Refer to Appendix H - Tree Management Plan, Tree Survey and Tree Protection Report

5.6 Project Delivery and Staging

As the VPCLXR project is a complex engineering project requiring significant construction lead times for all of the viaduct precast structural elements, the project has been split into separate development application phases. This initial phase seeks planning approval for the enabling early works and key viaduct structural elements, including piers, pier headstock and 'U' troughs and associated rail infrastructure, to ensure that essential enabling time critical construction work isn't unduly delayed by the more detailed design resolution process that is underway for the new train stations and station precincts, including public spaces and facilities within the ground level public realm, which will be the subject of separate future development applications.

6. Key Planning and Design Considerations

6.1 Relationship with Surrounding Urban Context

The VPCLXR project will elevate the Armadale Rail Line, within the Town, for a total length of 1,479 metres, extending from Mint/Archer through to the abutment at Biggs Street.

The area surrounding this section of elevated rail infrastructure is generally characterised by single storey residential development of a low to medium density on both the western and eastern sides of the Armadale Rail Line corridor. The Carlisle Hotel and Harold Hawthorne Community Centre are situated in close proximity to the Carlisle Train Station. The South Metropolitan TAFE Carlisle Campus and various existing commercial and light industrial developments are situated in close proximity to the Oats Street Train Station.

The surrounding area is of mixed character, there are a number of underdeveloped sites and vacant land parcels and there are therefore opportunities for new development in the area to leverage from this significant investment in public infrastructure. In this respect the VPCLXR project is anticipated to act as a catalyst for future growth and development investment within the Town in close proximity to the rail corridor and beyond. This application will specifically support this through allowing for the following outcomes:

- Removal of the Mint Street and Oats Street level crossings to facilitate safer vehicle and pedestrian movements in these locations; and
- Elevated rail infrastructure to allow areas to the east and west of the Armadale Rail Line to be connected via new high quality urban realm improvements that link established communities and facilitate desirable movement. The proposed ground level public realm treatments, inclusive of new public spaces and facilities will be the subject of future separate development applications.

6.2 Applicable Planning Framework

6.2.1 The Purpose and Intent of Applicable Planning Schemes

The following planning schemes are relevant to this development application:

- **Metropolitan Region Scheme:**
 - The MRS defines the future use of land and provides the legal basis for planning in the Perth Metropolitan Region. It also provides the regulatory planning framework that typically exempts all METRONET work⁵ inside railways reservations from the need for planning approval. Notwithstanding the exemptions provided by the MRS a PCA has been placed over parts of the subject site, which requires all works in the PCA to be approved by the WAPC, as mentioned in Section 5.2.
 - The VPCLXR project aligns with the reserve description for Railways as the project is providing upgraded public transport facilities that promote connectivity and accessibility.

⁵ METRONET work and 'Permitted development' under the MRS are defined to cover the same extent of works. 'Permitted development' for the purposes of land reserved for Railways under the MRS is defined as works "for the purpose of or in connection with a railway, but this does not include the construction or alteration of a railway station or any related car parks, public transport interchange facilities, or associated means of pedestrian or vehicular access".

- **Town of Victoria Park Local Planning Scheme No. 1:**

- The objectives and intentions of the Town's LPS is to control and guide development and growth in a responsible manner and in a manner which can initiate, accommodate and respond to change. The goal of LPS 1 is to ensure that the Town is recognised as providing a high level of services and amenities.
- One of the objectives of LPS 1 includes ensuring that planning at the local level is consistent with the MRS and wider regional planning strategies and objectives. In this respect, it is noted that the proposed VPCLXR project is for a new elevated rail within the MRS Railways Reservation and is consistent with wider regional planning strategies including Perth and Peel @3.5 Million to increase the capacity of Perth's metropolitan rail network and to and promote urban renewal in areas surrounding the upgraded rail infrastructure.
- As the reservation of the subject site is established by the MRS, LPS 1 does not provide specific requirements or objectives for the Railways Reservation. LPS 1 establishes the zonings for the surrounding land parcels which are in close proximity to the subject site.
- As this development application is being made within a PCA, development approval is not required under the local planning scheme. Further, this application relates only to the early enabling works and the viaduct structural component of the VPCLXR project, which are located solely within the railways reservation and do not interact with the adjoining land uses, accordingly the objectives of the local reservations and/or land use zones of LPS 1 are not directly relevant to this application. The development is considered to be consistent with the objectives of LPS 1.

6.2.2 Relevant State and Local Planning Policies

The following State and local planning policies and other identified planning instruments are relevant to this development application:

- State Planning Policy 5.1 - Land use planning in the vicinity of Perth Airport
- State Planning Policy 5.4 - Road and Rail Noise
- State Planning Policy 7.0 - Design of the Built Environment
- Local Planning Policy 10 - Pedestrian Walkway
- Local Planning Policy 29 - Public Art Private Developer Contribution
- Local Planning Policy 37 - Community Consultation on Planning Proposals
- Local Planning Policy 38 - Signs
- Local Planning Policy 39 - Tree Planting and Retention

The proposed development has been assessed against the planning framework documents listed above in Appendix C.

Refer to Appendix C – Planning Assessment

6.2.3 Orderly and Proper Planning and Preservation of Amenity

The principles of orderly and proper planning require that new development is a logical and efficient extension of existing development, and consistent with the planning vision and strategic direction for the locality. This project represents a significant investment by the WA Government in enhancing the capacity of the train network to support long term future population growth and urban consolidation, improving safety and congestion issues associated with existing level crossings and improving the amenity of the VPCLXR project area to support urban renewal and consolidation.

The VPCLXR project will decrease the footprint of the existing rail line, elevating it and concealing it within a viaduct. This will create a significant new opportunity for ground plane public realm revitalisation and improvements, inclusive of new public spaces and facilities.

Whilst this development application is limited to the early enabling works and the primary viaduct structure, specific regard has been had to pier sizing and placement to minimise their visual impact and to ensure a considered approach to legibility and safety concerns. The design has been carefully considered and well resolved not just from an engineering perspective, but also having regard to the principles of good design as set out in SPP 7.0.

Whilst feedback from community and stakeholder consultation has focussed on the broader train station and public realm design approach, it has also highlighted the importance of the project facilitating safe and pedestrian friendly connections across and along the rail corridor. The viaduct is key to delivering these connections and freeing up the land within the rail corridor for alternative public land use.

Given the above, the proposed development is considered to be consistent with the principles of orderly and proper planning.

6.3 Crime Prevention Through Environmental Design

The WAPC’s Designing Out Crime Planning Guidelines (DOCP Guidelines) were established in 2006 and are intended to be a readily useable, illustrated reference document, which demonstrates ‘good’ and ‘bad’ examples of design in the urban environment from a crime prevention perspective.

ALUA in consultation with key stakeholders has had regard for to Crime Prevention Through Environmental Design (CPTED) principles in relation to the proposed structure in terms of pier width, spacing, location and the preservation of sightlines.

The principles of CPTED will be even more relevant to the VPCLXR project as the design of the new train stations and precincts continues to evolve, Future development applications will consider the DOCP Guidelines in detail, specifically addressing both design and operational measures proposed to be put in place to ensure that safe places and spaces are provided for all users.

Notwithstanding the additional detail to accompany future development applications for the new train station and station precincts, the viaduct structures proposed as part of this application are integral to the overall outcome provided at ground level and how this will assist to create a safer more cohesive community. In this respect, the viaduct structure is anticipated to have the following positive impacts:

- Creation of high quality public spaces and facilities beneath the viaduct structures responding to and delivering the following:
 - Consideration having been given to designing out crime principles, promoting safe places and spaces through design;
 - Increased levels of pedestrian activity within new curated public realm areas, activating the area and providing additional passive surveillance opportunities; and
 - Increased levels of pedestrian activity within and around the new train station precincts.

Future development applications relating to the new train stations and station precincts will provide more information on specific measures proposed to create safe places and spaces as part of these locations.

It is acknowledged that the overall construction period associated with the VPCLXR project is long. Therefore, ALUA in consultation with key stakeholders are committed to ensuring that spaces surrounding the construction site are safe and fit for purpose to limit risks to pedestrians as far as practically possible. A Construction Management Plan (CMP) has been prepared by ALUA and addresses the safety of construction workers, pedestrians and road users using the area and the ongoing use of the rail line during the temporary construction period.

Refer to Appendix I – Construction Management Plan

6.4 Sustainability Approach

The METRONET Sustainability Strategy 2021 (Sustainability Strategy) aims to create a sustainable legacy for Perth through the planning, design, procurement, and construction of transport infrastructure, train stations and precincts.

Elevating the Armadale Rail Line through the VPCLXR project has had regard to the social, environmental and economic themes of the Sustainability Strategy. Noting that further information will be provided around the approach to sustainability for the new train stations and station precincts as part of separate future development applications, the viaduct structure is highlighted as being consistent with the Sustainability Strategy for the following reasons:

- **Connectivity Amenity and Liveability** – the removal of the level crossings will create safer, more efficient transport routes for the local and wider community.
- **Resilience and Adaptability** – the upgrades to the Armadale Rail Line will be able to service the longer trains that the PTA plan to introduce, and will promote growth and higher public transport usage within existing well established urban areas.
- **Environmental Values and BIO** – the pier and viaduct structure utilises efficiencies in its design to minimise the use of materials and minimise waste. New public realm areas, including public space and facilities will be opened up allowing for improved landscaping and increased tree canopy to address urban heat island effects whilst retaining existing trees where practically feasible.
- **Viable Communities** – ongoing community consultation has already and will continue to provide opportunities for the local community to be involved with the project outcome. The upgrades to the rail line will promote opportunities for economic and community growth in surrounding areas by providing easy access to modern high quality public transport infrastructure.

As the viaduct system replaces the traditional ground level rail line, more opportunities for greenspaces will be utilised to tackle climate concerns, increase connectivity and accessibility and create safer transport routes.

Once finalised, detailed landscaping plans and public realm design concepts for public spaces and facilities will be provided as part of the future development applications for the new train stations and station precincts. This explanatory information will be included in the application materials when they are advertised for public comment in due course.

7. Key Technical Considerations

7.1 Acoustic and Vibration Considerations

An Operational Noise and Vibration Assessment has been completed by ALUA and has been included at Appendix J. The purpose of this assessment is to indicate the extent of mitigation required to achieve compliance with the relevant noise and vibration criteria within the Town and the City. Further noise and vibration assessment work is yet to be completed for the City of Gosnells section of the project.

The report outlines the design response to the assessment of operational rail noise and vibration modelling during the Reference Design stage of the VPCLXR project. The assessment demonstrates that:

Predicted Future Rail Noise

Predicted future rail noise levels in the unmitigated scenario will exceed the:

- Daytime design noise level at a total of 28 receiver locations.
- Night-time design noise level at a total of 13 receiver locations.
- Maximum noise criterion at a total of 5 receiver locations.

Therefore, the following acoustic barriers (noise walls) are proposed:

- Noise Wall West No.1 is 1.5 metres high (above rail line) and approximately 88 metres long. It runs adjacent to the railway line and Mytilene Drive, Victoria Park, north of Miller Street within the Town.
- Noise Wall East No. 1 is 1.5 metres high (above rail line) and approximately 247 metres long. It runs adjacent to the railway line and Rutland Avenue, Lathlain, south of Miller Street within the Town.
- Noise Wall West No. 2 is 1.5 metres high (above rail line) and approximately 330 metres long. It runs adjacent to the railway line and Sevenoaks Street, Cannington, from Bent Street to Crawford Street within the City.
- Noise Wall East No. 2 ranges from 1.5 metres high to 2.0 metres high (above rail line) and is approximately 685 metres long, with the 1.5-metre high section being 628 metres long and the 2.0-metre high section being 57 metres long. It runs adjacent to the railway line and Railway Parade, East Cannington, from Gerard Street to Albion Street in the City.

Refer to Figure 17 below for noise wall location requirements.

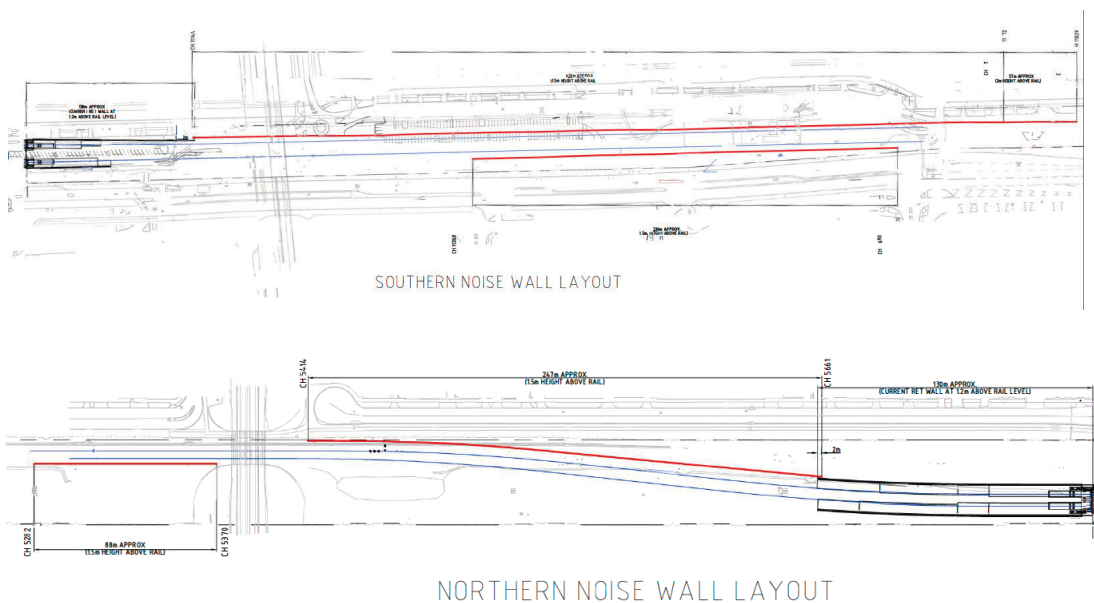

Figure 17. Noise wall location requirements for VPCLXR Project (excluding the City of Gosnells)

In the mitigated scenario, predicted rail noise levels achieve the LAeq,day, LAeq,night and LAm_{ax} at all receivers. Notably, all of the required noise walls to mitigate noise and achieve compliance with the rail noise criteria are located outside of the PCA boundaries and will be subject to METRONET works exemptions after the METRONET Act amendments take effect, however they have been documented within this application, consistent with the principles of transparency.

The noise wall heights noted in the Operational Noise and Vibration Assessment and documented above are the minimum heights that are needed to achieve the required acoustic performance outcomes for the VPCLXR project. The heights of these walls may be increased in the circumstance that there is a need for these walls to serve a dual purpose, such as for the provision of security barriers on boundaries or to address visual screening requirements. Typical noise walls for similar projects range in height from 1.5 metres to 4 metres. The corridor width and noise modelling results will be used to determine the height of the wall that is required at each location.

Noise walls will be set in from the corridor to allow for additional screening from planting, and to provide a better barrier of protection between the corridor and residential areas. Noise walls will not be located where public open space exists.

Vibration

A semi-analytical model will be used in the next phase of design to predict the differences in vibration and regenerated noise due to the suggested track-based mitigation options compared to the unmitigated ballasted (surface sections of the alignment) and direct fix slab (viaduct sections) tracks.

Corrections will be applied to the vibration levels to account for train speed; the transfer of vibration from the ground into a building; the amplification of vibration on a suspended floor; and the radiation of sound from the vibrating building.

Refer to Appendix J – Operational Noise and Vibration Assessment (2022)

Noise from fixed infrastructure

Fixed infrastructure associated with the passenger rail which are not part of the stations package will consist of the following:

- Power transformers
- Track switching equipment rooms (TSER)
- Communications equipment rooms (CER)
- Overhead line equipment (OLE) infrastructure.

Noise due to all fixed infrastructure will be assessed during the next phase of design against the *Western Australia Environmental Protection (Noise) Regulations 1997*.

7.2 Construction and Traffic Management

The project is to be principally constructed during an 18 month shut down period during which the rail line will be closed and there will be replacement bus services in operation. METRONET has publicly acknowledged that this shutdown process will be disruptive to the community however it was determined as the most appropriate option to deliver the new rail line quickly and safely. Temporary bus stops and bus interchanges will also be established during this period to support the replacement bus services that are operational during this time and until the new permanent bus stops and interchanges come on line as part of the VPCLXR project.

A CMP has been prepared by ALUA and describes the construction methodology for the VPCLXR project including the sequencing of project works, plant and equipment details used for each stage of construction, and how construction interfaces with the surrounding area will be managed.

Refer to Appendix I – Construction Management Plan

In general, the footprint required to construct the VPCLXR project will be confined to the railways reservation as far as practically possible, limiting any impacts to the surrounding area. Notwithstanding this, it is anticipated that temporary road closures will be necessary to complete certain elements of the project works.

Armadale Line Upgrade Project

Victoria Park Early Works Development Application No. 1 – Viaduct Construction and Enabling Works

The CMP provides traffic management strategies that will be deployed to coordinate temporary traffic management arrangements. A preliminary traffic management plan has also been prepared by ALUA and is included in the CMP.

A traffic engineer and supporting traffic supervisor will be embedded in the project delivery team to consider and minimise transport network impacts within the construction methodology and activities. The traffic management team will be responsible for:

- Advising on construction methodology and coordinating work activities to minimise impact on the road network.
- Engaging with key stakeholders and organisations on traffic management planning and design.
- Working with the community and stakeholder engagement team to effectively communicate traffic impacts and mitigation strategies.
- Liaising with authorities to identify other third-party works that may impact the project and coordinate works to minimise disruption to the wider road network, and
- Implementing specific mitigation practices which may include:
 - Traffic signal timing or phasing amendments;
 - A coordinated vehicle management strategy;
 - Real-time road network monitoring and action response plans;
 - Bus stop / route amendments and proposed mitigation; and
 - Rail replacement bus routes that circumvent the disruption caused by occupation works.

In addition to traffic related impacts from the construction phase of the project, the CMP also includes details on a number of other matters, including but not limited to:

- General lighting details;
- Maintenance during construction;
- Construction constraints;
- Temporary fencing and hoardings;
- Storage of materials;
- Construction site cleanliness;
- Fire precautions;
- Temporary works;
- Public amenity relocation;
- Site reinstatement;
- The process of undertaking dilapidation surveys and condition reports for properties and structures within 100 metres of the works; and
- Management of noise and vibration during construction.

There will be periods in which work is undertaken at night. Relevant approvals will be sought and all work outside of hours will be undertaken in accordance with a noise management plan.

Further detail can be referred to within the CMP at Appendix I.

Refer to Appendix I – Construction Management Plan

7.3 Geotechnical Considerations

A significant amount of testing has been undertaken including through cone penetration testing and bore holes to determine the ground conditions. This has been taking into account and informed the engineering design requirements.

7.4 Contaminated Land

A search of the Department of Water and Environmental Regulations (DWER) contaminated sites database determined that small portion of the subject site adjacent to Mint Street has been identified as a suspected contaminated site.

The basic summary of records has been included at Appendix L. The records state that:

A dissolved hydrocarbon plume extends from the source parcel of the Site (166 Rutland Ave, Carlisle) to the northwest. The plume extends beneath Archer St, 3 Archer St, 1 Archer St, Rutland Ave, the Railway Reserve and East Vic Park Primary School.

This site was reported to the Department of Environment and Conservation (DEC) as per reporting obligations under section 11 of the 'Contaminated Sites Act 2003', which commenced on 1 December 2006. The site classification is based on information submitted to DEC by March 2007 on the basis that 166 Rutland Avenue, had historically been used as a service station.

The identified restriction on use states that groundwater abstraction is not permitted at the source of the affected land because of the nature and extent of groundwater contamination.

Given that groundwater abstraction is not proposed as part of the construction activities or development, it is considered that the affected part of the rail corridor that is included in the subject site is suitable for the proposed development.

Refer to Appendix L – Basic Summary of Records

7.5 Water Management

Stormwater Management for the VPCLXR project be included in the future development applications for the public realm and stations surrounds. Notwithstanding this, the CMP details temporary stormwater management, water use and drainage arrangements for the entire VPCLXR project during the construction phases.

During the construction phases of the project, working room within the railway corridor will be significantly limited. Work zones will clash with the ultimate location of drainage basins/ swales across the project area. In these locations, basins will be constructed during a second phase of drainage works and will require temporary solutions to be installed to manage stormwater until the ultimate design can be constructed. The temporary drainage approach will consist of v-drains and basins where required as assessed by the design at that point in time.

Refer to Appendix I – Construction Management Plan

Water used by the ALUA for construction purposes will be obtained from sources other than the Water Corporation water supply service, wetlands or surface water bodies unless it can be demonstrated to the satisfaction of the PTA's Representative that alternatives are not viable, and that all required approvals have been obtained.

7.6 Services and Infrastructure

Major services will be avoided, protected or relocated during the construction phases of the project. This will include:

- ATCO gas high pressure and medium pressure gas mains;
- High and low voltage transmission and distribution Western Power lines;
- Water Corporation water, drainage and sewer mains;
- PTA Main Cable Route (MCR);
- Telstra, NBN, Optus, Vocus, NextGen and Western Power communication lines; and
- Town of Victoria Park, City of Canning and City of Gosnells stormwater network and water reticulation networks.

A number of new services and upgraded utility service connections will be required for the new train stations, public precincts, car parks, railway communications and supply lighting for the Principal Shared Path (PSP). All service related matters will be implemented by ALUA's Utilities and Services Team, who will be responsible for the following:

- Locate all services within the project footprint;
- Engage asset owners to design and construct relocation of assets where required;
- Engage asset owners and where required design and/or construct all new and upgraded utility connections for train stations, traction power and other assets;
- Provide effective management of service and utility relocations by third parties and ALUA;
- Construct the Water Corporation assets that require relocation or extension;
- Design and construct any protection work for utilities and services not being relocated and any works required to protect railway infrastructure if services develop leaks in the future;
- Ensure services that are remaining in place, both permanently and temporarily, are avoided and protected;
- Remove or make safe by grouting redundant services in the works area that have potential to impact on project works or existing assets; and
- If required engage asset owners and design and/or construct any additional services that require relocation.

Refer to Appendix I – Construction Management Plan

8. Conclusion

This report has been prepared by element, on behalf of ALUA, in support of a development application for the necessary early works and viaduct structure for the VPCLXR project, which represents a major upgrade to the Armadale Rail Line.

The proposed works will include the removal of the existing rail line and train stations within the subject site, to be replaced by a viaduct and associated infrastructure.

Based on the justification provided throughout this report, we respectfully request that the Town and the WAPC process this application for approval as expediently as possible, to ensure the timely delivery of these important enabling works to facilitate the VPCLXR project.

